

# GENPOWER<sup>®</sup>

G E N E R A T O R

## GASOLINE GENERATORS USER AND MAINTENANCE MANUAL



## **DEAR GENPOWER GENERATOR SET USER;**

Welcome to Genpower Family!

Thank you for choosing Genpower generator and hope your works will not be unfinished.

Genpower generator sets are produced in compliance with ISO 9001:2000 Quality Management System and “CE” norms and in an environment-friendly way compatible to ISO 14001:2004 Environment Management System.

Our generators are delivered to our end users by being subjected to a careful quality control and tests which are applied in every stage of production. We are attempting to continuously improve our product and provide a better service for you, with our staff specialized in their field of interests and in modern factory facilities.

Please read the operating manual carefully before initial starting of generator set and also recommend you have it be installed by our authorized service in order to avoid from any unfinished matter.

This operating manual, for engine service–maintenance and alternator service–maintenance books are delivered together with generator set.

This operating and maintenance manual was prepared in order to ensure users to easily handle the generator and help them how they are going to make its maintenance. This is not a workshop repair manual.

The generator is under guarantee for **2 (two) years or 1500 operating hours** provided the use of it in accordance with the matters stated in operating and maintenance manuals. Any repair or replacement of parts caused by any modification held on the generator without giving consent of the original manufacturer or by use of non-original parts are excluded from scope of guarantee.

We recommend you to make a periodical maintenance agreement with our authorized services which provide continuous service for 7 days/ 24 hours in order to have much more performance and prolonged life -cycle of generator.

Please comply with attention and warning indicators on the generator set and take necessary safety measures mentioned in this manual for your safety and your surrounding lives.

Information included in this manual may not contain all features belonging to the generator.

Genpower has the right of making any amendment to improve the product quality without notifying.

## **GENPOWER GENERATOR**

**“Keep this manual for later assistance”**

## **GENPOWER GENERATORS UNIQUE SUPERIOR FEATURES AND ADVANTAGES**

- ◆ **Half A Century Old Experience in Generator Production**

- ◆ Low-level Noise

- ◆ **Advanced Technology and High-Quality Diesel Engines**

- ◆ Low-level Exhaust Emission

- ◆ **Advanced Technology and High-Quality Alternators**

- ◆ Low Operating Costs

- ◆ **Flexible Control Card Suitable for All Kinds of Applications**

- ◆ Low Fuel Consumption

- ◆ **Reliable and High-Quality Technology**

- ◆ Low Oil Consumption

- ◆ **Compact, Silent, Patented Design Canopy**

- ◆ Tropical, 50 °C Radiator

- ◆ **Compatible to Heavy Duty Conditions**

- ◆ Water and Particulate Separated Fuel Filter

- ◆ **First Class Product Support**

- ◆ Durability

- ◆ **Abundant and Reasonable Cost Spare Parts**

- ◆ Global Network in Service and Maintenance

## **IMPORTANT GENERAL INFORMATION**

### ***Generator Rating Definitions:***

*Genpower generators are produced in compliance with; TS ISO 8528-1, 8528-4, ISO 8528-5, BS500, ISO 3046/1:1985, IEC 60034, NEMA MG-1.22, BS5514/1 standard.*

**Standby Power (ESP)** is defined as the maximum power available during a variable electrical power sequence, under the stated operating conditions, for which a generating set is capable of delivering in the event of a reliable utility power outage. over 24 hours of operation shall not exceed 70% of the ESP rating. Under the condition of generator`s periodic maintenance has done in compliance with manufacturers maintenance procedures, total operating time at 70% ESP rating shall not exceed 200 hours/year. For applications supporting an unreliable utility service, the Prime Power (PRP) rating should be used.

**Prime Power (PRP)** is defined as being the maximum power which a generator set is capable of delivering continuously whilst supplying a variable electrical load when operated for an unlimited number of hours per year. The permissible average power output over 24 hours of operation shall not exceed 70% of the PRP. Total operating time at 100% PRP rating shall not exceed 500 hours/year. At 12-hour operating time %10 overloading can be done in one-hour zone, total operating time at overloading with 10% PRP rating shall not exceed 25 hours/year.

**Limited Continuous Power (LTP)** Under the condition of generator`s periodic maintenance has done in compliance with manufacturers maintenance procedures, total operating time at %100 LTP rating shall not exceed 500 hours/year. No overload capability is available for this rating.

**Continuous Power (COP)** is defined as being able to supply utility power at a constant 100 percent load for an unlimited number of hours per year. No overload capability is available for this rating.



*Recommended to follow these instructions in selection and operation of generator;*

- Generator, In Continuous Power, under the condition of generator`s periodic maintenance has done in compliance with manufacturers maintenance procedures and is used original spare parts and oil in compliance with manufacturer`s catalogues, may operate maximum %70 load at PRP.
- Generators shall not operated under the level of %50 at PRP rating. This may cause extreme oil consumption in engine, after in a short while permanent and unrecoverable damages may occurs.
- Dual or triple sync, equally aged and with fault redundancy systems should be chosen if the power output necessity is 1000 kVa and higher.



***ATTENTION! NEVER LOAD GENERATOR TILL TEMPERATURE OF WATER REACH 60 °C IN MANUAL OPERATED GENERATORS.***

# 1. PART: SAFETY MEASURES

## 1.1. INTRODUCTION

\* Generator groups produced by our company have been designed and conceived by prioritizing all sorts of safety of lives and property.

\* Generators should be installed and used in accordance with maintenance and operating rules stated in this catalogue both in terms of using the generator economically for a long-term and ensuring continuous safety of life and property. Required safety measures should be taken in advance during the installation, usage and maintenance. Safe operating responsibility of the generator set belongs to people using and maintaining it. Provided that instructions, methods and safety rules in this manual are complied with, risk of accident will decrease.

\* Otherwise, unexpected defects and accidents which may result within serious injured and death of people and damage on the equipment. Please have your generator used and maintained by well-trained people who issued or authorized persons in order to prevent these occasions.

\* Please plan any part, machine or engine you are operating in a way to ensure easy access to every point. Take pre-safety measures about how you can avoid from exposure to occasions like touching with rotating parts, burning and cut with sharp edges while checking out the engine. Ensure that covers of turbo compressor driving shaft, pump shaft, fan belts and winglets among engine components are fitted.

\* Never operate your generator when it is broken down and in unsafe conditions. Always isolate accumulator negative (-) lead terminal by separating from the accumulator. Bring attention of people by hanging a **WARNING/CAUTION** sign on the engine or its neighboring.

\* Never make any maintenance or repair while the generator set is operating. Turn off the generator and take all safety measures before any maintenance initiated.

\* Never have unauthorized persons repaired and maintained, this will cause damage in your generator and also be out of from scope of guarantee. We recommend you to use our authorized services providing 7/24 service.

## 1.2. **ATTENTION! DON'T DO THE FOLLOWINGS:**

- \* Don't start the engine indoors. Exhaust gases are odorless and can be deadly as they contain carbon monoxide.
- \* Do not insert your hands and feet into moving or rotating parts.
- \* Do not store, pour or use gasoline near open flames or appliances such as stoves, water heaters or sparking devices.
- \* Do not refuel in places such as poorly ventilated rooms. Do this in an open area.
- \* Do not refuel while the engine is running. Allow the engine to cool for 20 minutes before filling the gas tank. Store fuel in safe containers.
- \* Do not remove the fuel tank cap while the engine is running.
- \* Do not start the engine in the presence of gasoline odor or other explosive conditions.
- \* Do not start the engine if it is overflowing or dripping gasoline. Move the generator away from the stream and block ignition until the gasoline has evaporated.
- \* Do not carry the generator from one place to another with gasoline in the tank.
- \* Do not smoke while refueling.
- \* Do not run the engine at excessive speed. This can lead to accidents.
- \* Do not touch the throttle lever, links or parts that can increase speed.
- \* Do not change the engine speeds selected by the manufacturer.
- \* Do not control sparking (ignition) by removing the spark plug or spark plug wire. Use a tester for this job.
- \* Do not turn (run) the crankshaft by removing the spark plug. If the engine is choked, turn the throttle to "FAST" position and run.
- \* Do not hit the flywheel with a hard object while it is operating, it may break. Use the correct tool for servicing.
- \* Do not run the engine without a muffler. Check frequently and replace if necessary. If there is a muffler deflector, check it periodically and replace it with the correct deflector if necessary.
- \* Do not run the engine in the presence of flammable materials around the muffler.
- \* Do not use generators that do not have a spark arrester installed in the silencer in forest, groves and grassy environments. The spark arrester must be maintained by the user for effective operation.
- \* Do not touch the hot muffler, cylinder or cooling fins as this will cause burns.
- \* Do not operate the engine without the air cleaner, air cleaner cover and/or carburetor air intake cover (on Sno/Gard engines).

## 1.3. **ATTENTION! DO THE FOLLOWINGS:**

- \* To prevent accidental starting, disconnect the spark plug wire when servicing the generator. If your generator is a system with accumulator (E and TE series generators), remove the negative (minus) terminal of the accumulator.
- \* If your generator is accumulator started, do not neglect accumulator maintenance and cleaning. Keep the accumulator away from sparks, especially during charging. Accumulator acid is corrosive. It is especially dangerous for the skin and eyes.
- \* When repairing the electrical circuit is required, first disconnect the cables connected to the battery terminals.
- \* Clean the cylinder cooling fins and speed governor parts as they can affect engine speed.

- \* Pull the starter cord slowly until you feel resistance. Then quickly pull the handle to avoid kickback and hand injuries. For safety reasons, make sure that there is no one around the starter.
- \* Check the muffler periodically to make sure it is working properly. Worn leaking muffler should be repaired or replaced.
- \* Use fresh gasoline. Stale fuel can cause gumming and leaking in the carburetor.
- \* Check the fuel connections and gaskets for cracks and leaks. Renew if necessary.
- \* When the battery-started generator is not running, always remove the ignition key to prevent accidental starting.
- \* Always keep the fuel cock closed when you do not start the generator.
- \* Accumulator compartments boxes are manufactured in a safe way. Do not allow any occasion which may cause bare flame or electric arc near the accumulators. Hydrogen gas emitted from the accumulators may cause very serious injuries since it is so combustive and inflammable. Never **disconnect** lead terminals, impact on and bend over them while the engine is **starting** or operating.
- \* Have sufficient amount of **fulfilled** fire **extinguisher** present near to the generator.

#### 1.4. MOVING COMPONENTS AND IRRITATING MATERIALS:

- \* As a general maintenance rule; ensure gasoline engine is on STOP state or its covers are installed on it. Never operate engines **without protection guard** which are disassembled except the case that exceptional maintenance and settings must be performed.
- \* Coming close to an operating engine is a safety risk. Remember wide and loose clothes, long hairs may cause serious accidents by being put on rotating components.
- \* Putting tools or equipment down on operating engine due to incaution may lead to serious injuries in case of close contact to the engine.
  - \* Avoid from touching with operating engine exhaust system.
  - \* Install materials for safety and protection purpose disassembled during the service on their places before **starting** the engine.
  - \* Avoid contact gasoline, oils, cooling water and accumulator electrolyte used in the engine with your **bare** body.
  - \* Wear **protection** gloves and oil proof clothes while engaging with these works.
  - \* Oils, especially used oils **influence under the skin and so** may lead to irritation and eczema on skin.
  - \* Thoroughly wash your skin after contact with oil and use protective creams.
  - \* Always use face mask and acid proof clothes while **working** with the accumulator.
  - \* Hot oils may cause burns. Do not touch hot oil, your skin may burn. Ensure there is no pressure in the system before starting to work while operating with the lubrication system.

#### 1.5. EXHAUST GASES:

- \* Breathing exhaust gases is toxic and dangerous. Operate the generator on OPEN air or in environments with a good air circulation.
- \* Take attention that exhaust gas outlet points do not **exhaust** to human **living** areas or near to air intake channels.
- \* Do not operate the generator in the exhaust system having gas **leakage**.

#### 1.6. ELECTRIC SHOCK AND FIRST AID:

##### 1.6.1. *What Is First Aid?*

In the event of an accident or life-threatening situation, the treatment without medicines is called first aid until the assistance of the medical staff is provided, in order to prevent life from getting worse or worse.  
FIRST AID APPLICATION IS ABSOLUTELY NOT USED.

##### 1.6.2. *What Is The Purpose In First Aid?*

- \* Protection and maintenance of life
- \* Prevent deterioration of the situation
- \* Facilitate the healing process.

##### 1.6.3. *What Are The Features And Responsibilities Of The First Aider?*

- \* He must be calm and unhurried.
- \* Keep the patient calm.
- \* Determine whether there is a danger that evaluates the environment.
- \* Do not endanger the safety of his / her life.
- \* Organize the people in charge to inform health institutions, fire and security.
- \* Evaluate the condition of the patient and begin appropriate first aid.
- \* Ensure that the patient arrives at the health facility as soon as possible.

##### 1.6.4. *What are the basics of First Aid?*

- \* Opening of the breathing passage

- \* Correcting the respiratory system.
- \* Ensuring activity of the circulatory system.

### 1.6.5. First Aid In Electric Shock

- \* First ensure your own (first-aid) safety.
- \* Turn off the source of electricity, if possible.
- \* If not, move the source away from you and the person, using a dry, nonconducting object like plastic or wood.
- \* Begin CPR if the person shows no signs of circulation, such as breathing, coughing or movement.
- \* Apply a bandage. Cover any burned areas with a sterile gauze bandage.

### 1.6.6. First Aid for Carbon Monoxide Poisoning

- \* The patient is immediately moved to fresh air.
- \* Deep breathing is carried out in the fresh air.
- \* CPR is applied to patients who are unable to breathe or breathe.
- \* Cover the top of the body to prevent the patient from chilling.
- \* The patient shall be sent to the health center immediately.

### 1.6.7. First Aid for Bleeding

- \* If the wound is on the arm or leg, raise limb above the heart, if possible, to help slow bleeding.
- \* Apply direct pressure on the cut or wound with a clean cloth, tissue, or piece of gauze until bleeding stops.
- \* Apply a tourniquet if the bleeding is severe and not stopped with direct pressure in 5 minutes.

### 1.6.8. First Aid for Minor Burnings

- \* **Cool the burn.** Hold the burned area under cool (not cold) running water or apply a cool, wet compress until the pain eases.
- \* Remove rings or other tight items from the burned area.
- \* Don't break blisters.
- \* **Bandage the burn.** Cover the burn with a sterile gauze bandage (not fluffy cotton)

## 2. PART: BEFORE STARTING:

- \* GENPOWER generators have been produced in international standards.
- \* Each generator has a group identification plate. Serial number, qualifications, weights and manufacturing date of generators are written on this group plate. Use this serial number in spare parts, repair claims, interviews and at your demands.
- \* It is recommended to use high quality detergent oils classified as SE, SF, SD or SC. Detergent oils keep the engine clean and prevent gumming and deposits. Nothing should be added to the recommended oil. The viscosity of the lubricating oil used should be selected in accordance with the ambient temperature range in which the engine operates.

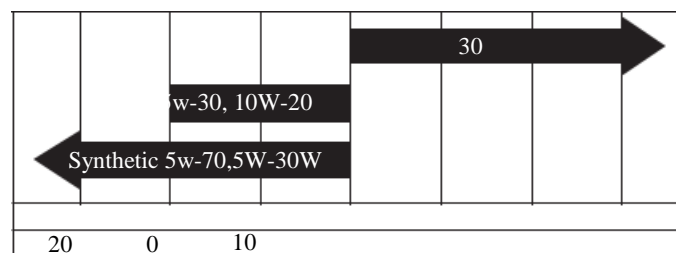

Figure 1

### 2.1. FILLING OIL:



**ATTENTION!** Your generator has been shipped without oil. Before using, be sure to fill in the oil. Do not ship with oil.

- \* Put the generator on a flat surface.
- \* Clean up around the mouth of the oil tank.
- \* Remove the oil filler plug or rod, fill the oil slowly. If there is an oil plug, fill up to the overflow point. If there is a oil dipstick, fill it to the FULL point on the dipstick. Do not overfill.

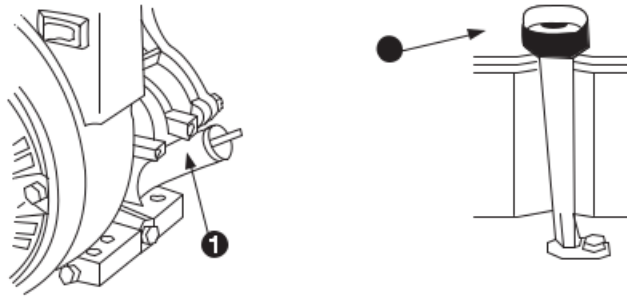

**Figure 2**

- \* Put the oil plug or dipstick in its place.

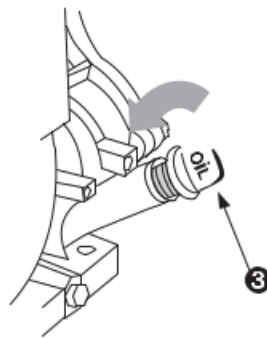

**Figure 3**

## **2.2. CHECKING THE OIL LEVEL:**

- \* Put the generator on a flat surface.
- \* Remove the dipstick and wipe it with a clean cloth.
- \* Put the dipstick back in place.
- \* Take it out again to check the oil level.
- \* While engine running, the dipstick should be firmly seated in its socket.

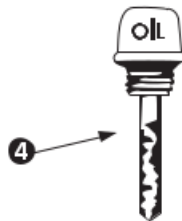

**Figure 4**

## **2.3. GASOLINE RECOMMENDATIONS:**

- \* Your generator runs efficiently with all gasoline used for automotive.
- \* It is recommended to use gasoline with an octane rating of at least 77. Do not mix oil with fuel.
- \* Use clean, fresh and unleaded gasoline.

- \* Purchase the amount of fuel to be used in the 30-day period. This ensures fuel freshness and the required fuel viscosity according to the season.
- \* When unleaded petrol is not available, leaded petrol can be used. Unleaded gasoline prolongs valve life as it reduces combustion residues.
- \* Do not use gasoline containing alcohol. If alcohol is to be used with the fuel, the gasoline should not contain more than 10% ethanol and should be drained when the engine is not in use.
- \* Do not open the fuel cap while the engine is running. Do not fill the tank to the overflow point. Leave about 5 mm of the tank space for fuel expansion.

**2.4. RECOMMENDATIONS FOR AN EFFICIENT PERFORMANCE:**

- \* Keep the generator flat while filling, storing and operating with oil and fuel.
- \* Do not use pressurized starting fluid.
- \* Use oil suitable for the temperature.
- \* Do not start the engine with a low oil level.
- \* Run the generator at no load (idle).
- \* Use fresh fuel.
- \* A hot battery has more starting capacity than a cold battery.
- \* If the engine is cold, make sure to adjust the choke fully.
- \* A hot engine requires less choke than a cold engine.

**3. STARTING GENERATOR:**

**3.1. To open the fuel cock:** Turn the fuel cock to the "ON" position as shown in the figure.

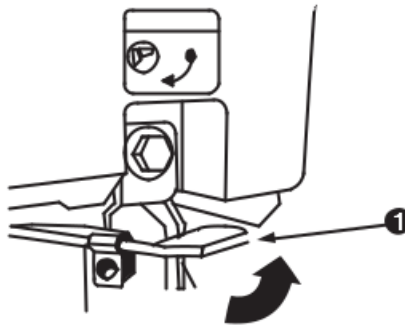

Figure 5

**3.2. Stop Switch:** Set the stop switch to the "ON" position as shown in the figure.

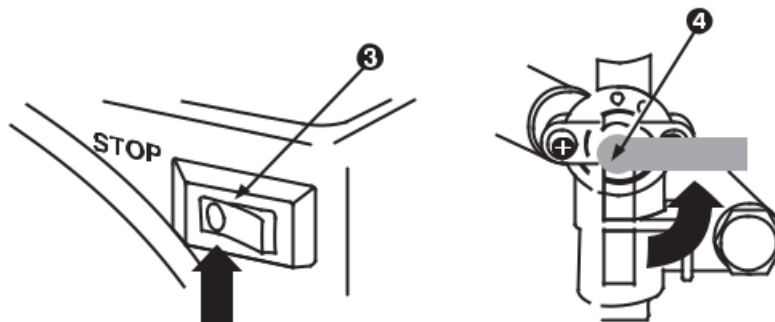

Figure 6

**3.3. Choke Control Arm:** Move the manual choke arm to the "CHOKE" position.

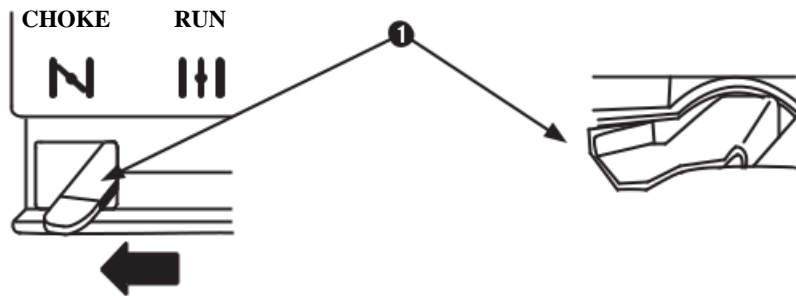

Figure 7

**3.4. Throttle Control Lever:** The throttle control lever is adjusted and locked in accordance with the frequency of the generator. Do not change the setting except for maintenance time and when it is not deemed necessary.

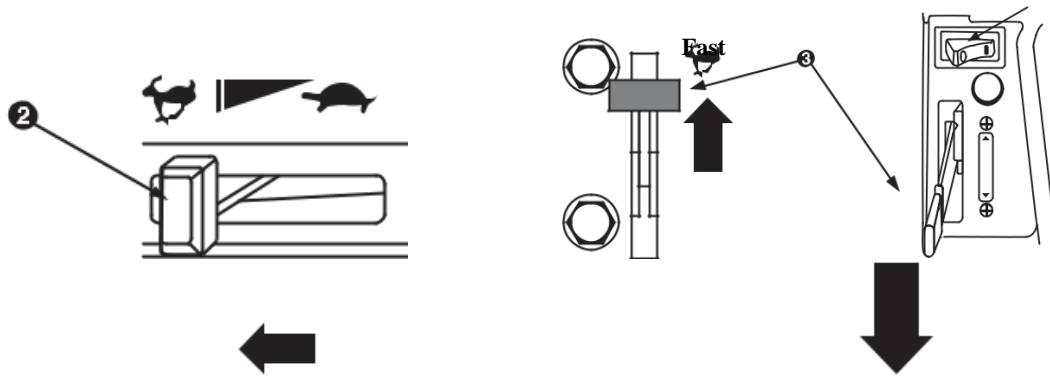

Figure 8

**3.5. Oil Level Protection Equipment:** If the oil level is lower than normal, the stop and start button will flash when the engine is wanted to be started. In this case, by checking the oil dipstick or checking the oil plug add oil until it overflows from the plug. Do not fill any more.

**3.6. Recoil Starting:** Gently pull the starter lever until you feel resistance. Pull until it meet the pressure and prevent kickback, pull quickly and start the engine. Repeat the same steps if necessary. After starting the engine, move the choke lever to the "RUN" position.

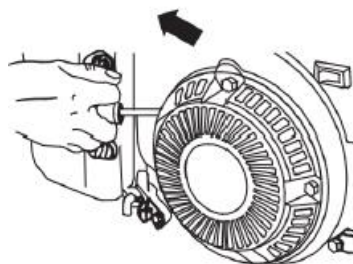

Figure 9

**3.7. Electric Starter:** Turn the key to the Start position. Best starter life provided by short operating cycles used for a few seconds. Long operation (more than 15 seconds) may damage the starter motor. Do not crank repeatedly. At least crank for the battery to recover itself. If the engine does not start after a few tries let it cool down for a minute. When the engine is running set the choke to the "RUN" position.

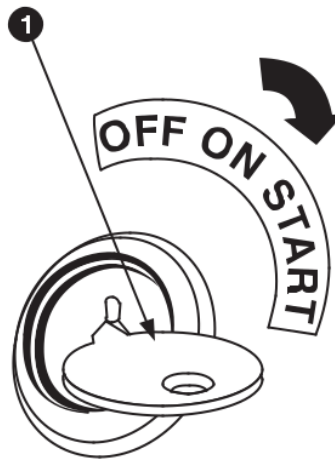

Figure 10

**4. STOPPING GENERATOR:**

- \* Before stopping the generator, always disconnect it from the load.
- \* Turn the ignition switch to the "OFF" position or,
- \* If equipped; move the choke lever to SLOW then STOP position.
- \* Do not use the choke to stop the engine. If choke used, explosion may occur due to the rich mixture. This is harmful to the engine.
- \* Close the fuel cock.

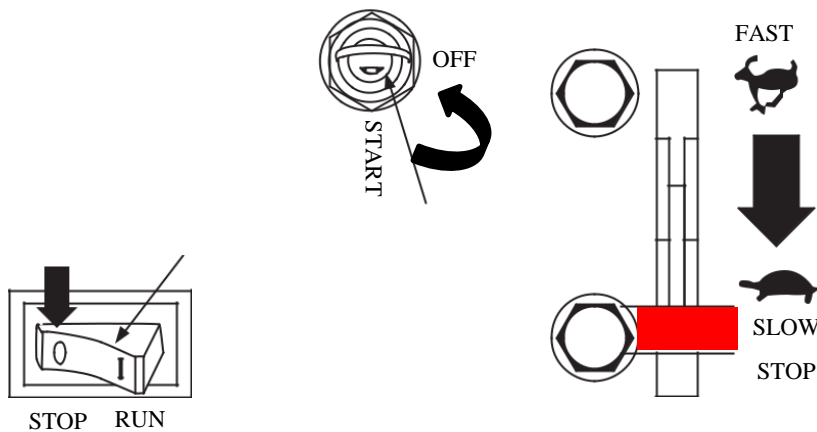

Figure 11

**5. MAINTENANCE:**

- \* General maintenance of the generator is described in this section.
- \* Always have authorized persons or authorized services maintained your generator set. Note that guarantee will be void in case of maintenance, repair and setting made by unauthorized services or persons.
- \* Always use original spare parts in maintenance and repair. Never use non-original parts or those approved by Genpower in written form.
- \* Guarantee of the generator set will be void as a result of damages caused by non-original maintenance or repair parts.

- \* Comply with safety measures mentioned in previous sections while performing the maintenance.

**⚠ ATTENTION!** *When servicing your generator, disconnect the spark plug wire from the spark plug to prevent the engine from starting suddenly. Disconnect the accumulator, if any. Take safety precautions and follow them.*

**5.1. Check Oil Level Regularly:** Check every 5 hours of operation or daily. Make sure the oil level is just right.

**5.2. Oil Change:**

- \* Replace oil after the first 5 hours of use.
- \* Under normal operating conditions, engine oil should be changed every 50 working hour.
- \* At high temperatures and loads the oil should be changed every 25 hours.
- \* When the engine is warm drain the oil by removing the oil drain plug and replace the plug. Fill the oil with the recommended oil.

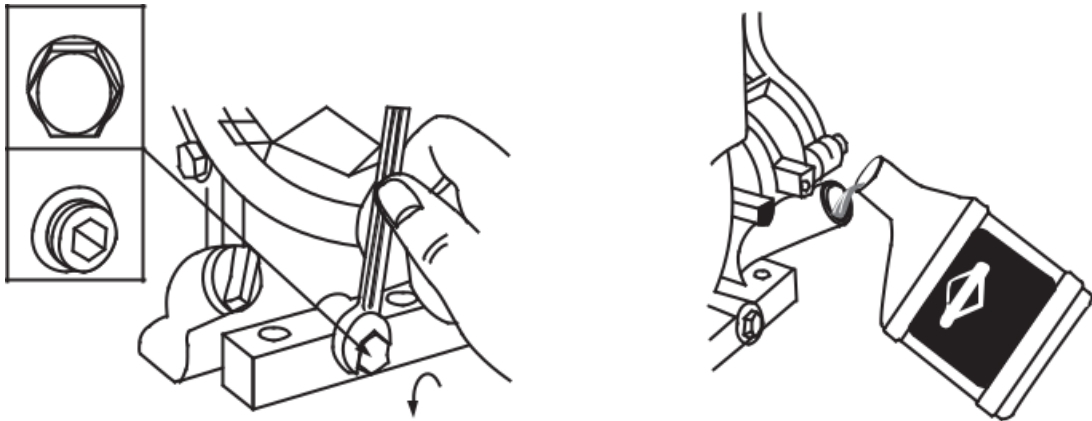
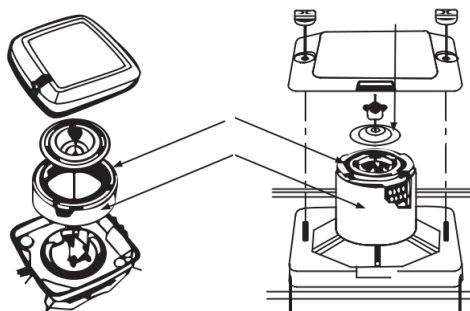

**Figure 12**

**5.3. Air Filter Maintenance - Dual Element Air Filter:**

- \* If your engine has it, after every 25 hours of operation perform pre-cleaning maintenance.
- \* If with pre-cleaner, service the cartridge every 100 hours. If not do the maintenance every 25 hours.

**⚠ ATTENTION!** *Perform maintenance more frequently in dusty conditions.*



**Figure 13**

**5.4. Pre-Cleaner Maintenance:**

- \* Unscrew the filter attachment screws.
- \* Carefully remove the pre-cleaner and wash it with liquid detergent and water.
- \* Absorb engine oil and wring out any excess oil with an absorbent cloth.

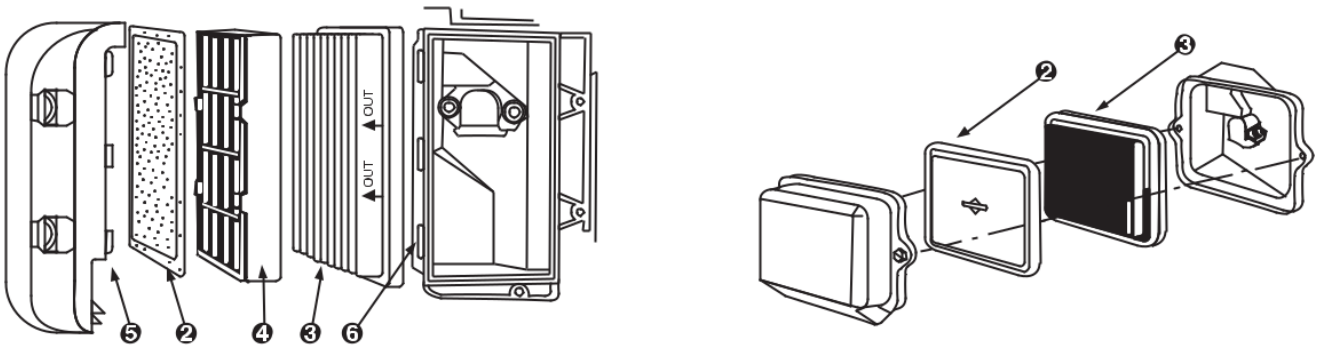

Figure 14

### 5.5. Cleaning of Generator:

- \* Remove dirt and debris with a cloth or brush and clean it.
- \* Water jet washing does not recommended due to engine fuel system with alternator winding and electrical equipment may break down.
- \* Do not keep combustible parts on or near of exhaust muffler.
- \* Generator cooling provided by the air flow passing over it. Therefore, the air ducts on the engine body and the alternator air outlet windows must be open and clean.
- \* Grass and dirt can clog the starter guard and the air cooling system becomes inadequate, especially as a result of extended maintenance time.
- \* Every 100 hours or every season, remove the starter guard and clean the area shown in Figure 15.

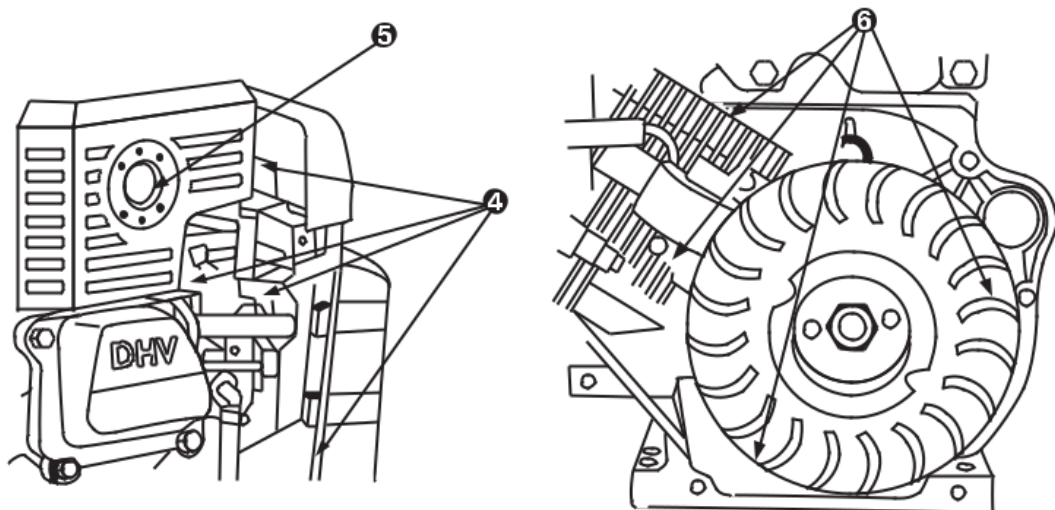

Figure 15

**5.6. Sparking Plug Replacement or Maintenance:** Replace or clean the spark plug after every 100 operating hours. Adjust the spark plug gap to 0.76 mm with a feeler (Figure 16). Do not destroy the clean spark plug. Clean the spark plug by scraping or with a wire brush.

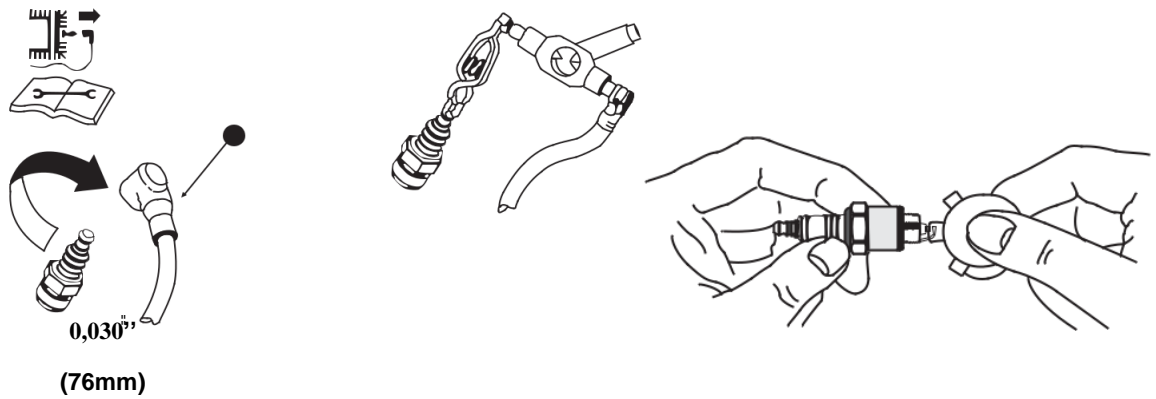

Figure 16

**6. MONO PHASE GENERATOR CONNECTION DIAGRAM:**

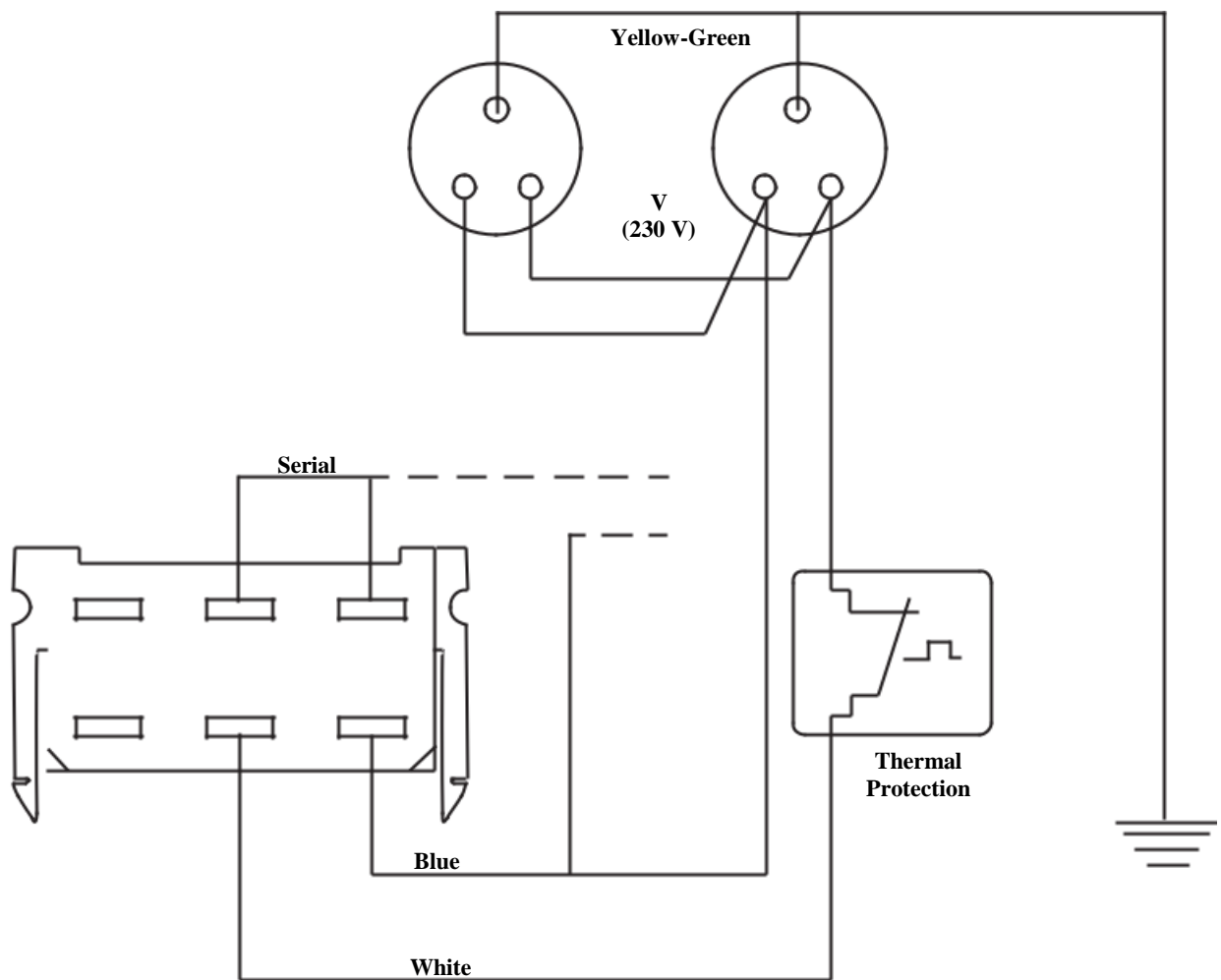

Figure 17

***THANK YOU FOR CHOOSING GENPOWER GENERATOR SETS, WE WISH FOR YOU TO USE YOUR GENPOWER GENERATOR THROUGH LONG AGES IN ACCORDANCE WITH THESE OPERATING AND MAINTANCE MANUAL.***

**GENPOWER**<sup>®</sup>  
GENERATOR



**GENERAL DIRECTORATE**

ASO II. Industrial Zone  
2010. Street No: 18  
06909 Temelli-Sincan/Ankara, TURKEY  
Phone/ Fax: +90(312) 641 32 22 - 641 32 23  
genpower@genpower.com.tr  
www.genpower.com.tr